

# Everglaze Installations

Quality Windows and Doors since 1979



## Secondary Double Glazing System

The Everglaze Secondary Glazing system is a popular cost effective option to keep your existing windows and doors but reduce noise pollution and retain heat into your home. Our specially designed system is quick and easy to install, comes in a wide range of colours and a full spectrum of glass alternatives. All secondary windows are factory assembled and made to measure to ensure a perfect fit.

### Why is Secondary Glazing required.

Every window and door has an acoustic rating, this is the amount of noise that travels through your existing window when they are in their closed position. Newer windows have double glazed sealed units (two panes of glass) which reduces the noise level but even these still allow noise to penetrate into your home, single glaze windows (one pane of glass) offer poor noise reducing qualities and poor thermal qualities. Secondary is widely used in greater noise locations such as airport flight paths, Road traffic noise, passing train lines or busy streets.

### How it works.

By installing secondary glazing you are adding another barrier to block noise, reduce heat loss or cold draughts entering your property, this is mainly achieved by this new void between your existing windows / door and new installed secondary glazing.

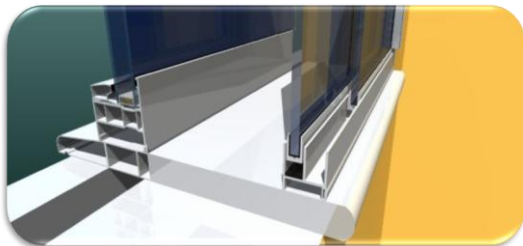

Cross cut drawing between existing Window (left) and installed secondary (right).

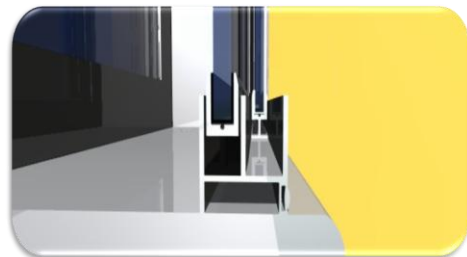

Cross cut drawing showing Horizontal Sliding secondary glazing.

# Everglaze Installations

Quality Windows and Doors since 1979



Our system range consists of

Horizontal Sliders, Vertical Sliders, Tilt / Slide option available for Easy Cleaning  
Lift Out, Hinged System, Fly Screens

## Outerframes

Various outerframes are available to suit every home.

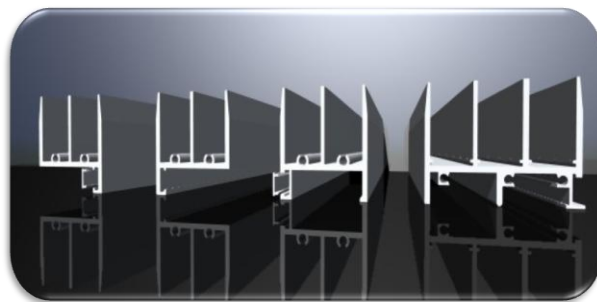

## Horizontal Sliding Secondary Glazing

From 2 Pane to 4 pane sliders each window can be manufactured to line up with your existing window so your existing views are not compromised. Heavy duty interlocking stiles available for added strength to tall secondary.

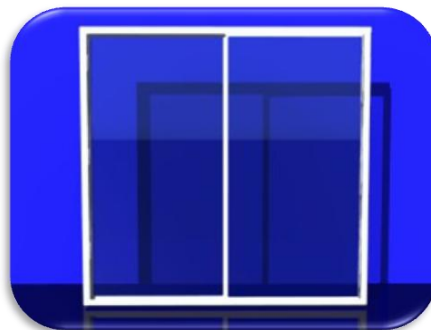

# Everglaze Installations

Quality Windows and Doors since 1979



## Vertical Sliding Secondary Glazing

This option is basically similar to the horizontal sliding secondary glazing but these slide upwards and downwards. Manufactured with counter balancing springs to hold the sashes in position and ease of movement. Each spring (2 per sash) are tensioned to hold the correct weight and smooth movement.

Vertical sliding secondary glazing comes with the added option of tilt action for ease of cleaning, unlock the sash and it tilts inwards towards you for easy access to the glass between secondary and existing window.

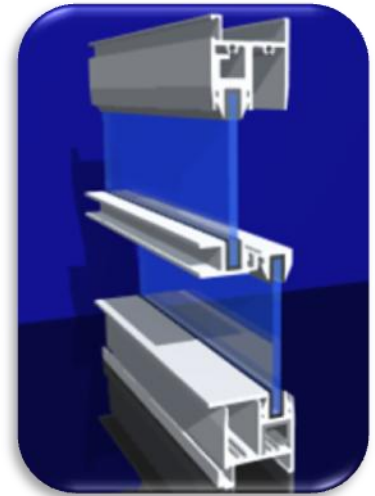

## Lift Out Secondary

This option is normally used where fixture windows (non opening) are installed. The secondary is fitted in place and the lift out action is available for cleaning. The sections are slim and again easy to install.



# Everglaze Installations

Quality Windows and Doors since 1979



## Hinged System

Similar to the fixed option but this secondary is fitted with side hinges. This allows the secondary to be unlocked and opened again for ease of cleaning. Again this type is slim and easy to fit.

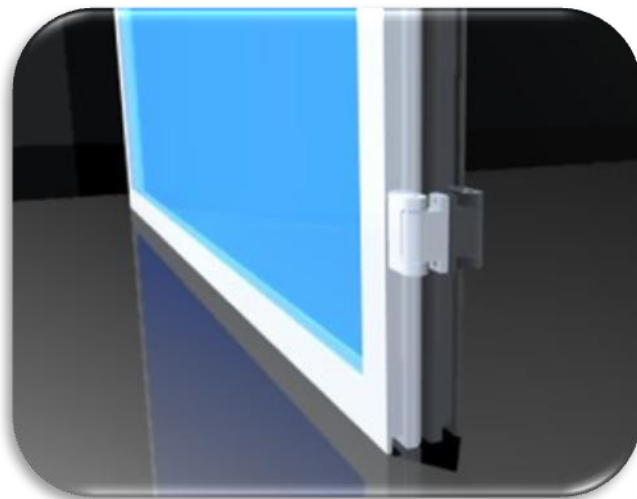

## Glass

All of our secondary glazing can accommodate glazing to suit 4mm, 6mm Toughened Safety Glass, mirrored glass, clear, obscured (pattern glass) and 6.4mm Laminated Safety Glass. An option for 6.8mm Silence glass is also available for secondary glazing that requires the highest noise reducing qualities

## **About US**

Everglaze Installations was founded in 1979 and have been manufacturing Secondary Glazing for many years completing countless installations. We manufacture the complete range of replacement double glazed windows and doors in aluminium and UPVc. A maintenance service can be arranged to repair a faulty existing window or replacement of a broken sealed unit. We DO NOT employ pushy sales people which along with our service has given Everglaze Installations a Strong name and contender within the glazing industry. We carry out contracts for the construction industry that equates to our million plus turn over. Every part of our company applies the same level of care and attention from single replacement glass to our vast contracted work.

Thank you for requesting a brochure and taking time to get to know about us a little better and our services. Please do not hesitate to contact us should you have any questions or if you would like to arrange a visit.

ALL OUR QUOTATIONS ARE FREE AND WITHOUT OBLIGATION.

## **Contact Us**

You can contact us by

Phone: 0207 791 3100

Fax: 0207 790 4292

Web Site: [www.everglazeinstallations.co.uk](http://www.everglazeinstallations.co.uk)

Email: [everglazeinstallations@btconnect.com](mailto:everglazeinstallations@btconnect.com)

Or you can visit us

Everglaze Installations Limited  
352-355 Yorkshire Road  
London  
E14 7LR

**Everglaze Installations Limited**  
**352-355 Yorkshire Road**  
**E14 7LR**

**0207 791 3100 Fax: 0207 791 4292**

**Web: [everglazeinstallations.co.uk](http://everglazeinstallations.co.uk)**

**Email: [everglazeinstallations@btconnect.com](mailto:everglazeinstallations@btconnect.com)**